

Catalogue

Company Introduction

Section Drawing & Structure Drawing

60 Casement System (Thickness 2.0mm)	1
60H Casement System (Thickness 2.5mm).....	2
66/66H Casement System (Thickness 2.5mm).....	9
70M Casement System (Thickness 2.8mm)	13
80/80T Sliding System (Thickness 2.0mm / 2.2mm).....	15
88/60 Sliding System (Thickness 2.0mm)	20
88T/60T Sliding System (Thickness 2.2mm).....	20
109/60 Sliding System (Thickness 2.5mm).....	21
Reinforcement Drawing.....	27
Window Calculation.....	29
I & E Value and Weight List.....	32

Section Drawing



60 Casement System (Thickness 2.0mm)

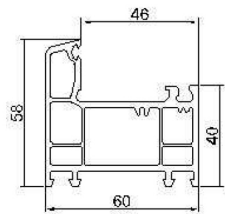

frame
JP-017
1.00Kg/m

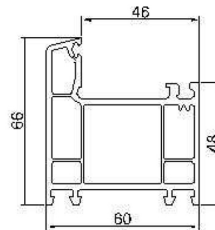

door frame
JP-017-1
1.13Kg/m

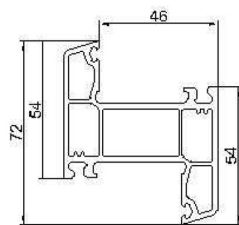

Z mullion
JP-147
1.01Kg/m

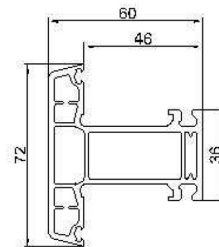

mullion
JP-019
1.02Kg/m

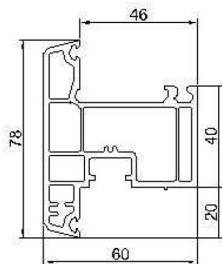

outward window sash
JP-015
1.15Kg/m

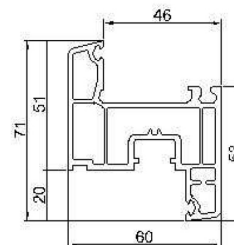

inward window sash
JP-016
1.08Kg/m

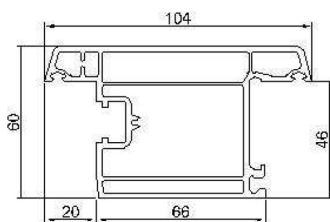

outward door sash
JP-018
1.50Kg/m

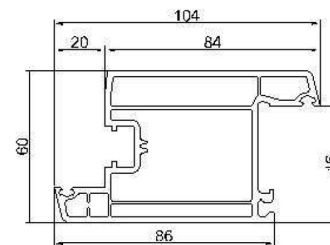

inward door sash
JP-038
1.45Kg/m

Section Drawing

60H Casement System (Thickness 2.5mm)

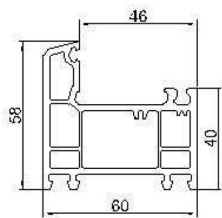

frame
JP-017H
1.09Kg/m

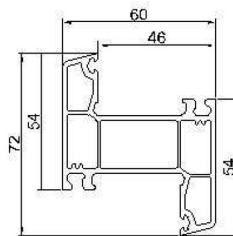

Z mullion
JP-147H
1.16Kg/m

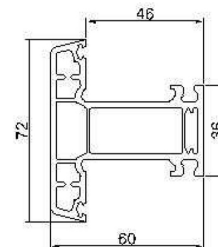

mullion
JP-019H
1.13Kg/m

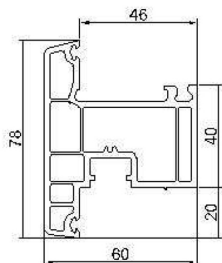

outward window sash
JP-015H
1.25Kg/m

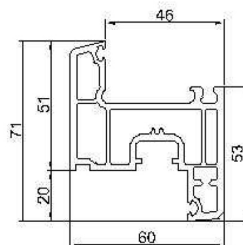

inward window sash
JP-016H
1.18Kg/m

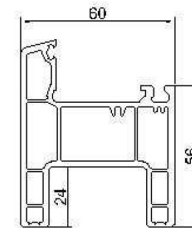

intergrated frame mullion
JP-298H
1.30Kg/m

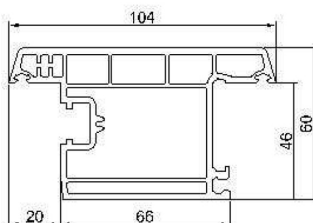

outward door sash
JP-018H
1.65Kg/m

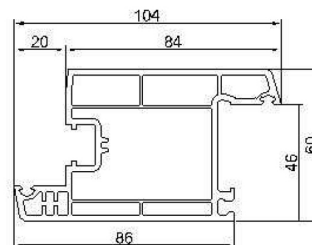

inward door sash
JP-038H
1.68Kg/m

60/60H Casement System GB

5mm glass

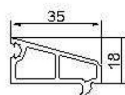

GB35mm
JP-022-1
0.27Kg/m

10mm glass

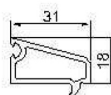

GB31mm
JP-021-1
0.24Kg/m

17mm glass



GB23mm
JP-106
0.20Kg/m

19mm glass



GB20mm
JP-023-1
0.195Kg/m

22mm glass



GB18mm
JP-181
0.185Kg/m

Section Drawing



60 Casement System Auxiliary Profiles

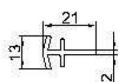

coupling
JP-031-1
0.11Kg/m

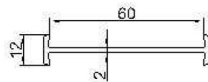

coupling
JP-215
0.25Kg/m

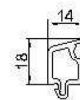

frame GB
JP-196
0.18Kg/m

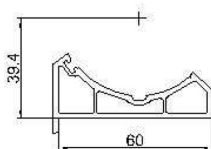

coupling
JP-090
0.53Kg/m

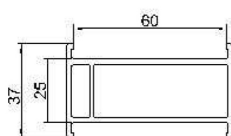

coupling
JP-049
0.68Kg/m

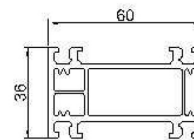

basic frame
JP-195
0.81Kg/m

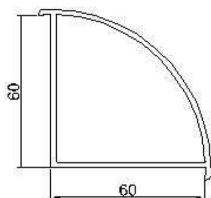

coupling
JP-051
0.68Kg/m

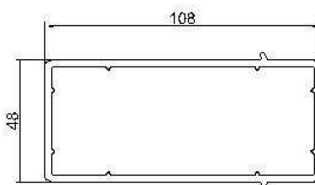

coupling
JP-130
1.30Kg/m

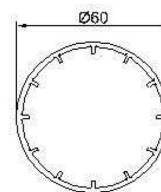

coupling
JP-013
0.62Kg/m

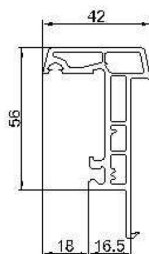

float mullion
JP-046
0.69Kg/m

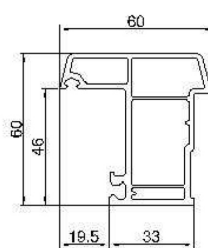

float mullion
JP-220
0.94Kg/m

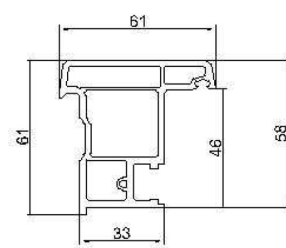

float mullion
JP-220-1
1.09Kg/m

Section Drawing



60 System Joint Drawing

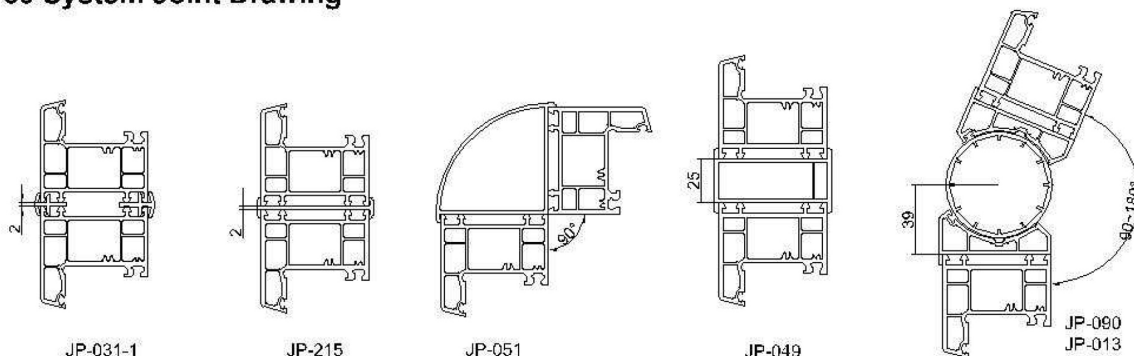

Trans-system Joint Drawing

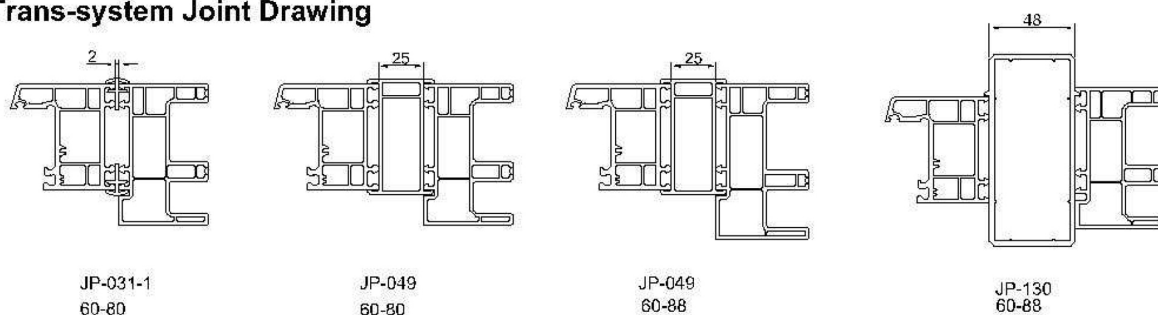

Door Panel Profile

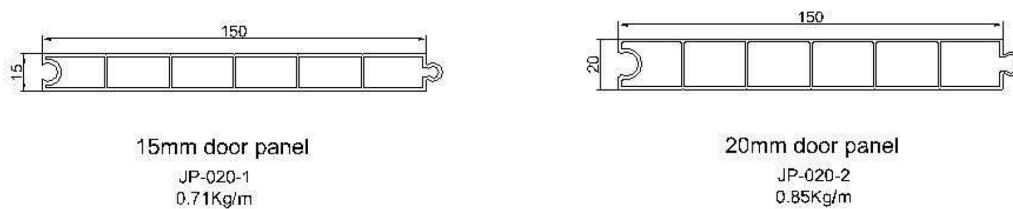

Louver profiles

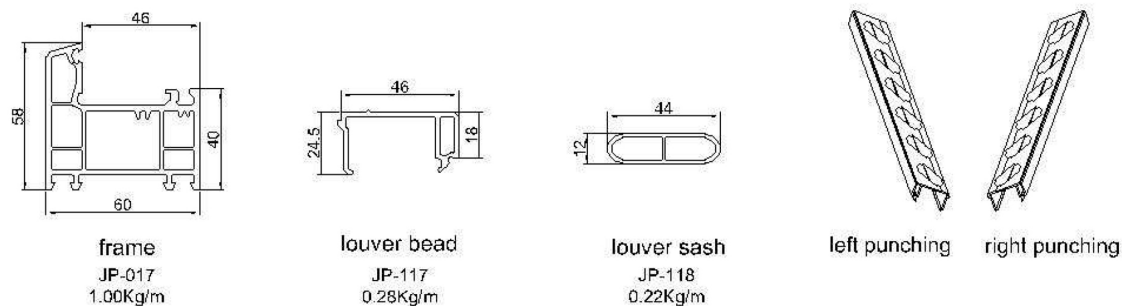

60 Casement System-Inward Window

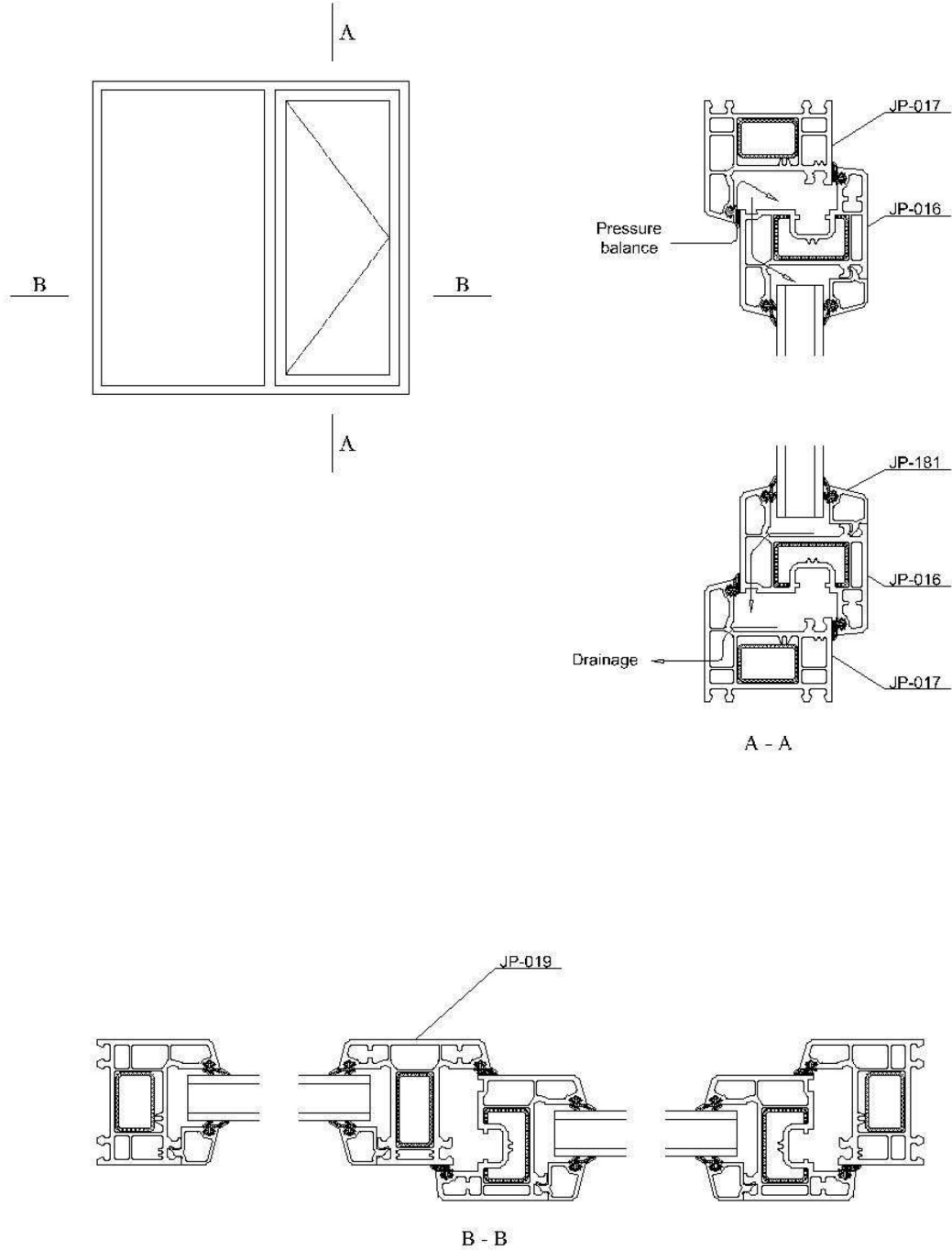

Structure Drawing

60 System-Outward Window

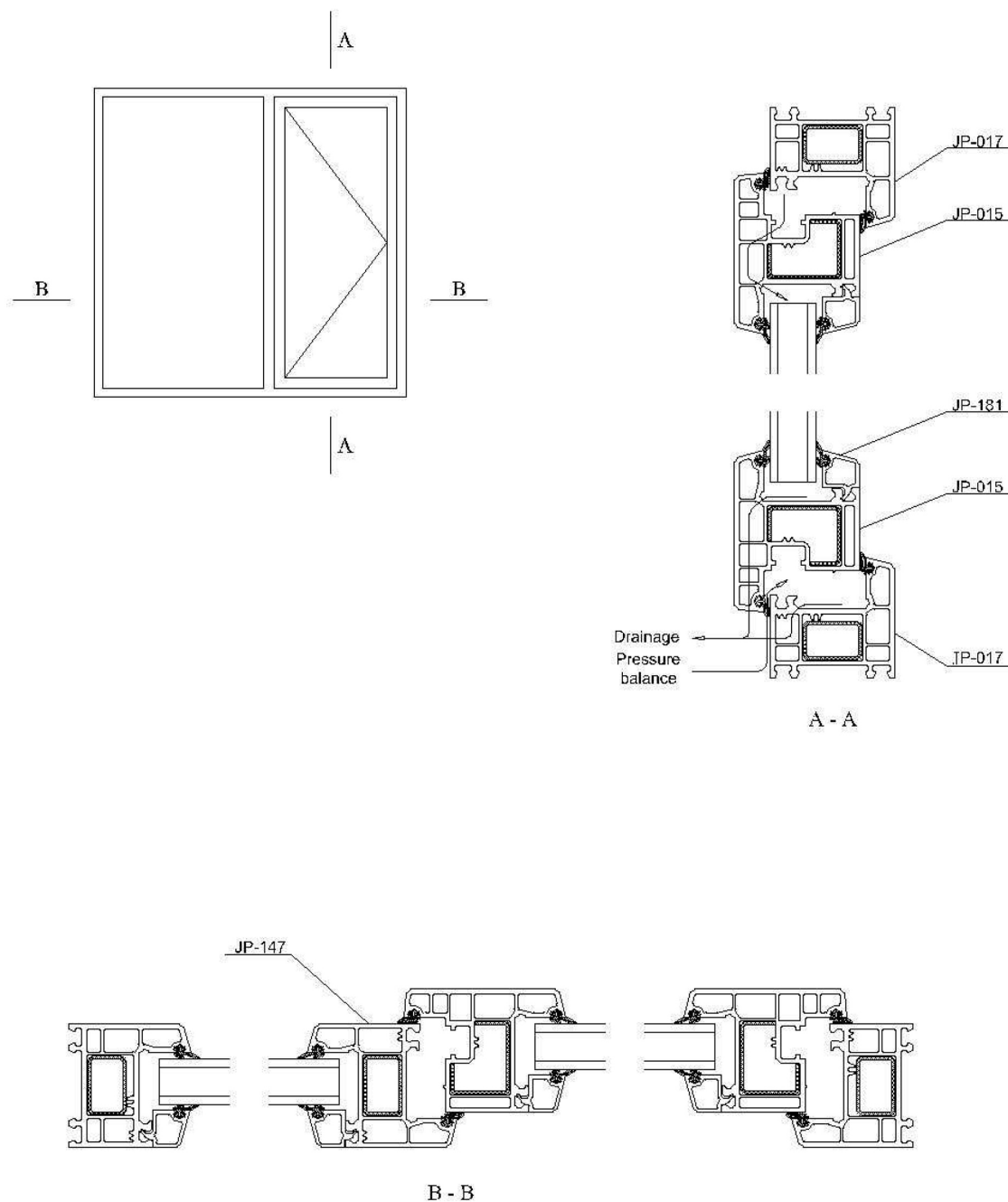

Structure Drawing

60H Casement System-Outward Door

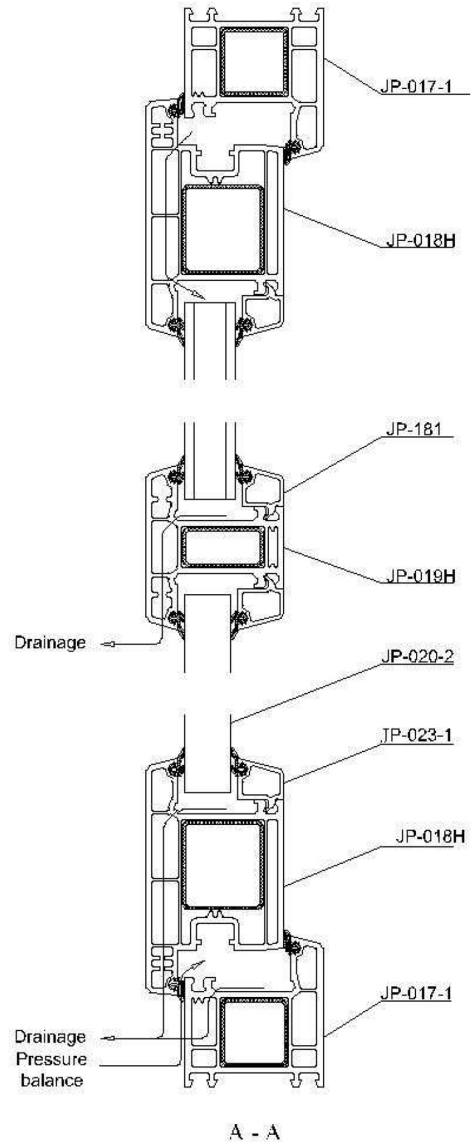
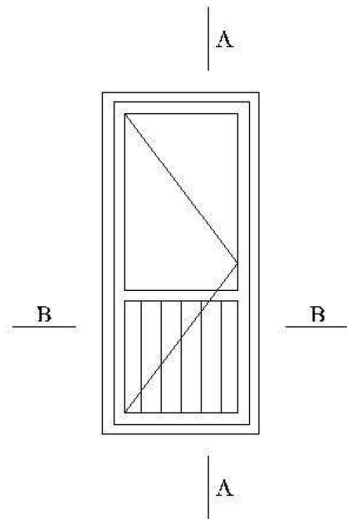

A - A

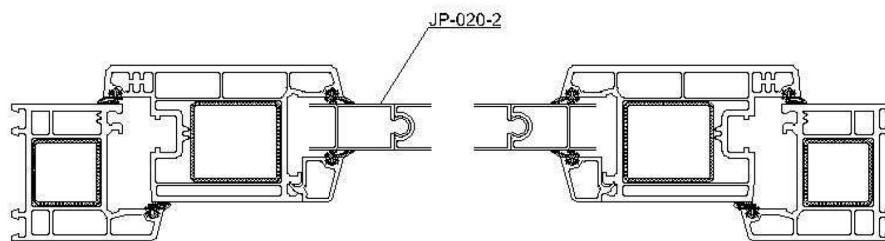

B - B

Structure Drawing

60 Casement System-Inward Door

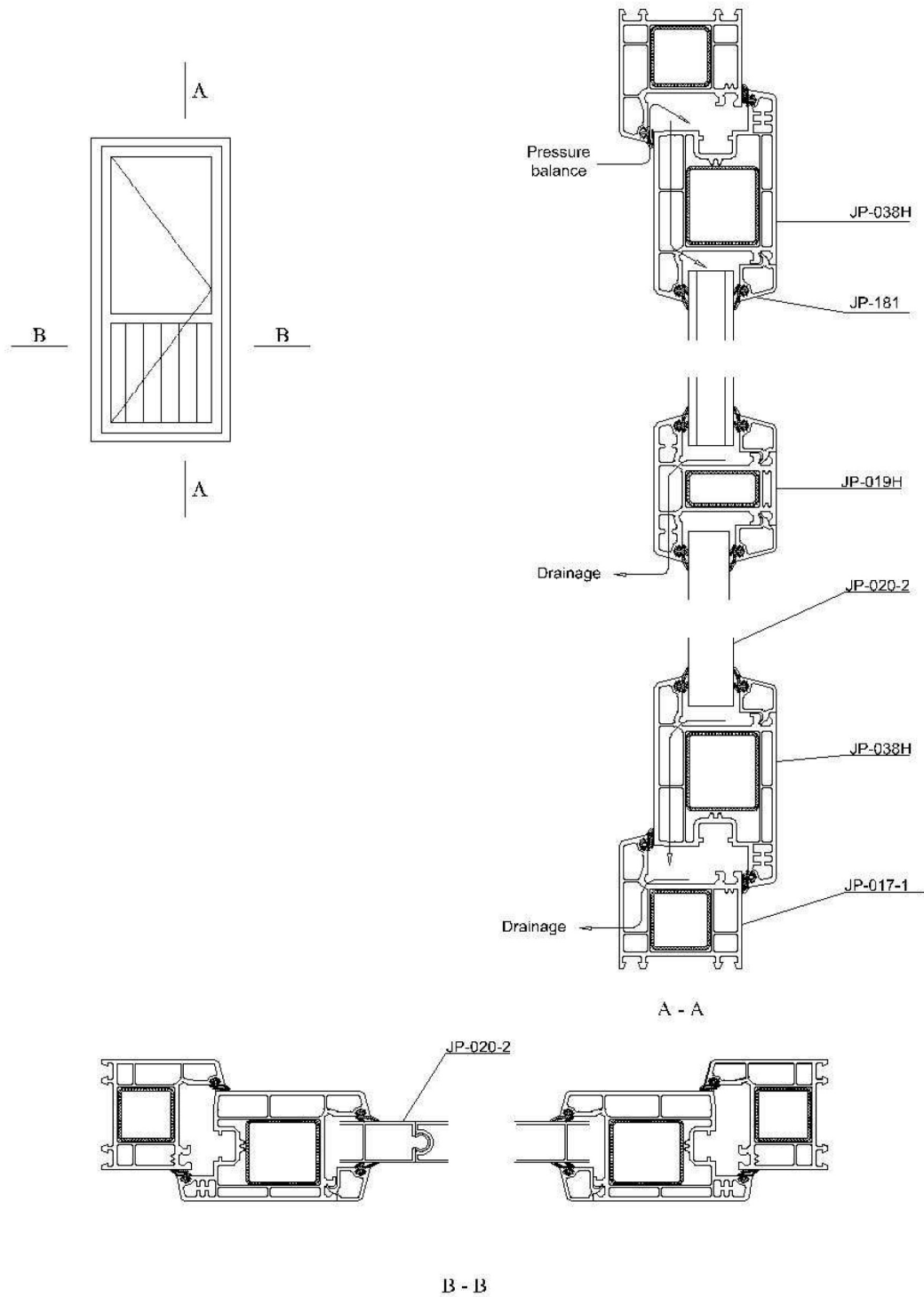

Section Drawing

66 Casement System (Thickness 2.5mm)

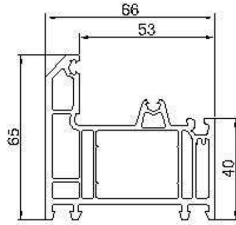

frame
JP-135
1.26Kg/m

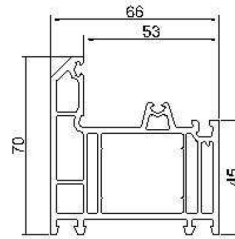

high frame
JP-135-1
1.34Kg/m

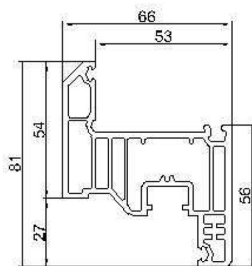

inward window sash
JP-137
1.37Kg/m

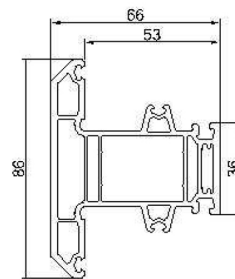

mullion
JP-136
1.45Kg/m

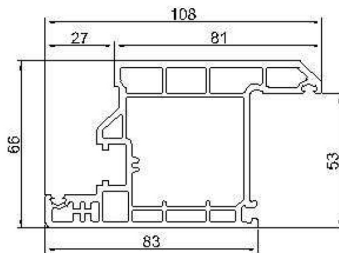

inward door sash
JP-212
1.79Kg/m

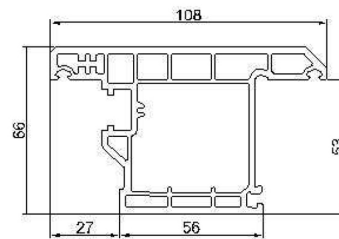

outward door sash
JP-213
1.73Kg/m

66H Casement System (Thickness 2.5mm)

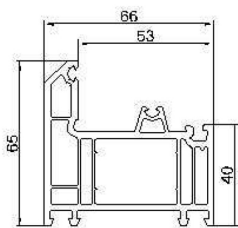

frame
JP-135H
1.36Kg/m

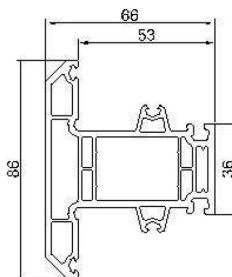

mullion
JP-136H
1.54Kg/m

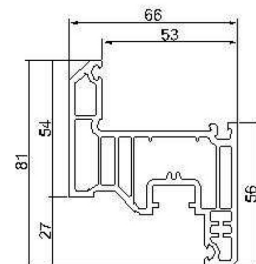

inward window sash
JP-137H
1.45Kg/m

Section Drawing

66/66H Casement System GB

36mm glass

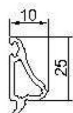

GB10mm
JP-139
0.19Kg/m

36mm glass

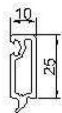

GB10mm
JP-140
0.20Kg/m

22mm glass

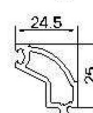

GB25mm
JP-166
0.25Kg/m

66 System Auxiliary Profiles

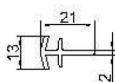

coupling
JP-031-1
0.11Kg/m

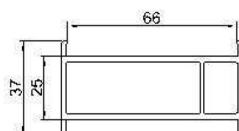

coupling
JP-167
0.70Kg/m

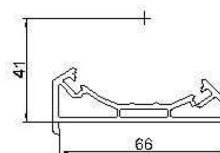

coupling
JP-214
0.58Kg/m

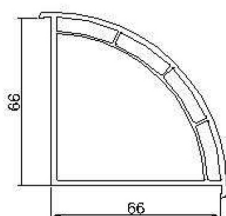

coupling
JP-163
0.96Kg/m

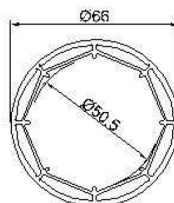

coupling
JP-219
0.95Kg/m

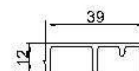

glazing pad
JP-138
0.20Kg/m

66 System

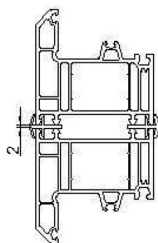

JP-031-1

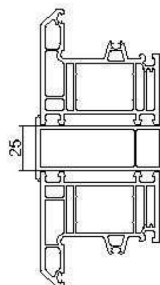

JP-167

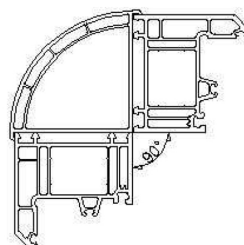

JP-163

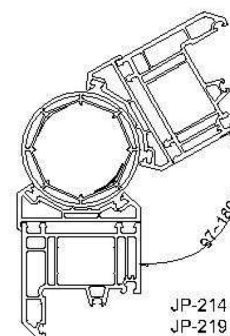

JP-214
JP-219

Structure Drawing

66 System - Inward Window

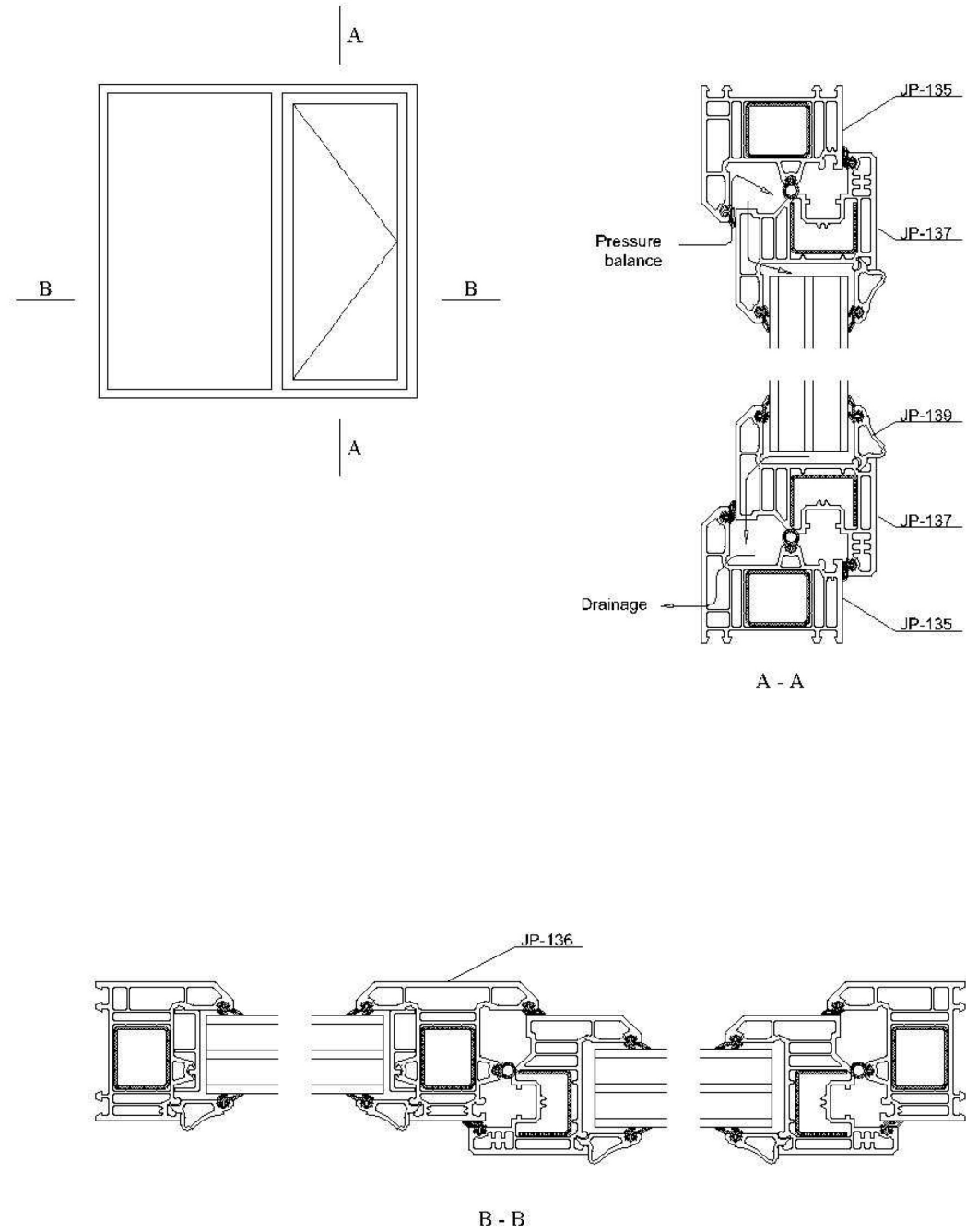

Structure Drawing

66 System-Outward Door

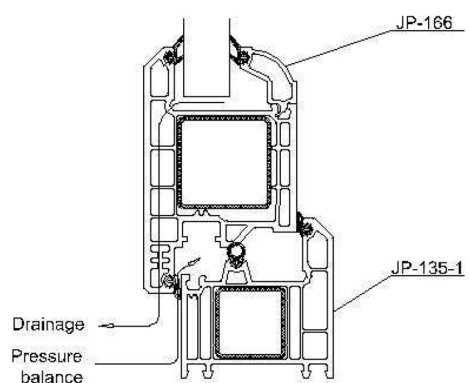
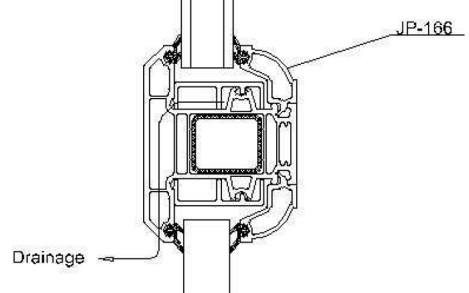
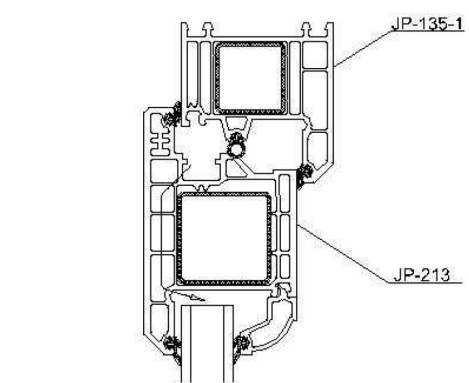
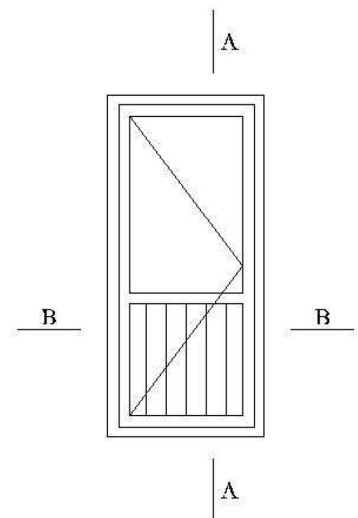

A - A

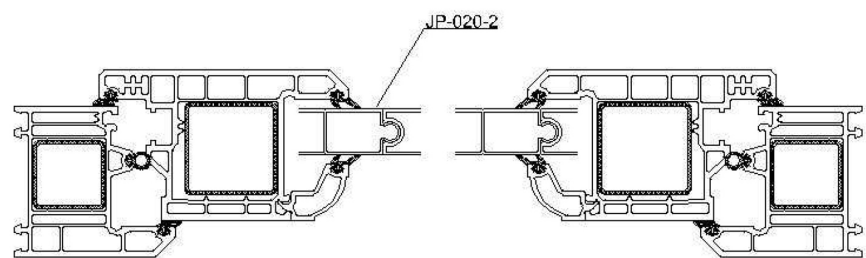

B - B

Section Drawing

70M Casement System (Thickness 2.8mm)

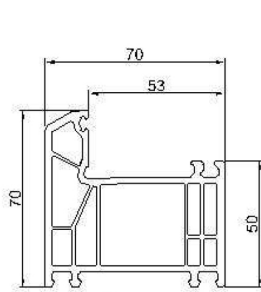

frame
JP-326M
1.48Kg/m

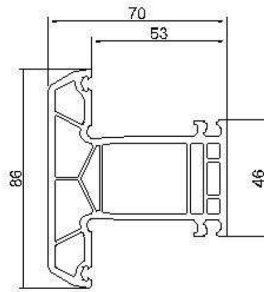

mullion
JP-327M
1.64Kg/m

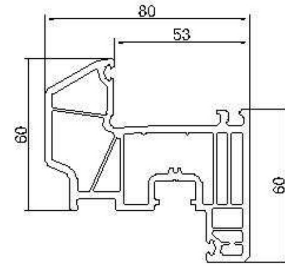

window sash
JP-328M
1.72Kg/m

70M Casement System GB

31mm glass

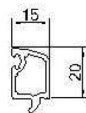

GB15mm
JP-329
0.20Kg/m

25mm glass

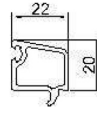

GB22mm
JP-330
0.235Kg/m

70 System Auxiliary Profiles

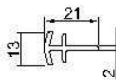

coupling
JP-031-1
0.11Kg/m

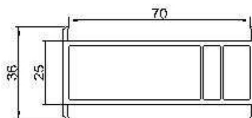

coupling
JP-332
0.66Kg/m

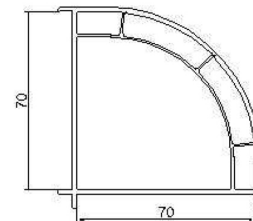

coupling
JP-333
1.03Kg/m

70 System Joint Drawing

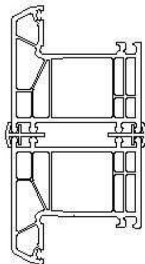

JP-031-1

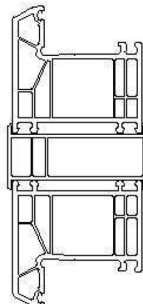

JP-332

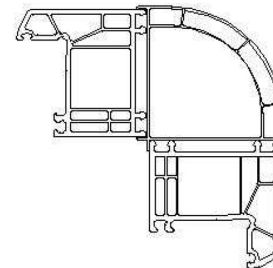

JP-333

Structure Drawing



70M System-Inward Window

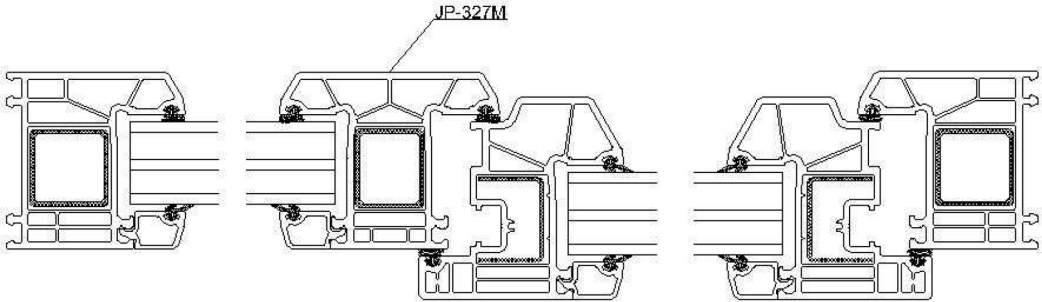
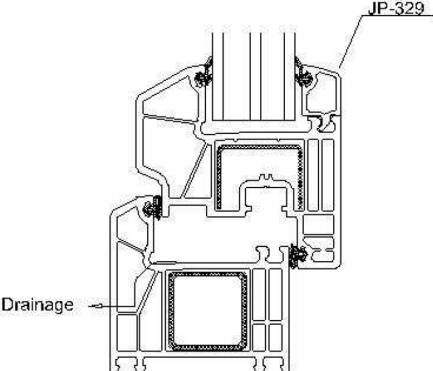
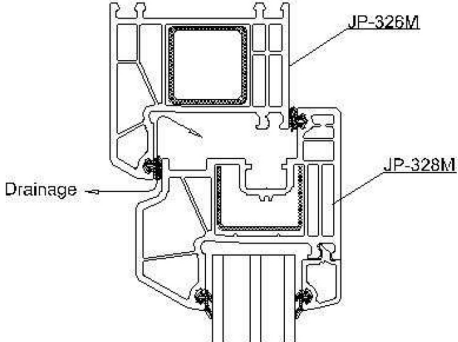
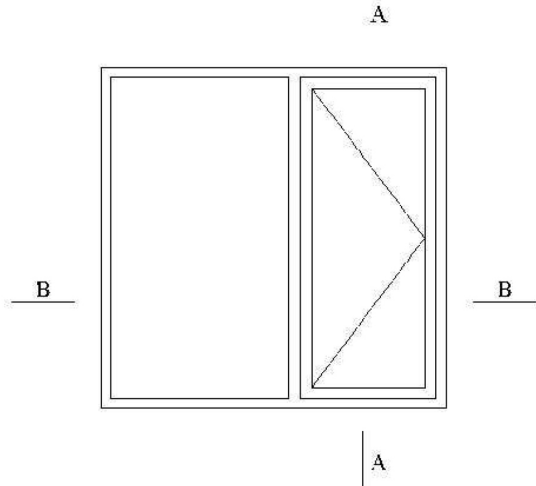

B - B

Section Drawing

80 Low Sliding System (Thickness 2.0mm)

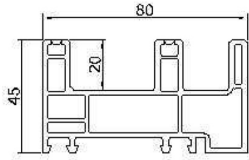

frame
JP-044
1.10Kg/m

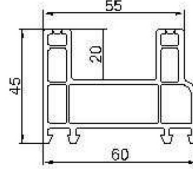

frame
JP-102
0.84Kg/m

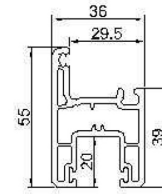

sash
JP-045-1
0.69Kg/m

80 Sliding System (Thickness 2.0mm)

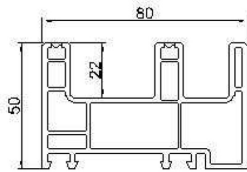

frame
JP-111
1.17Kg/m

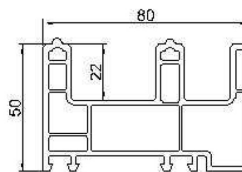

plastic-track frame
JP-230
1.30Kg/m

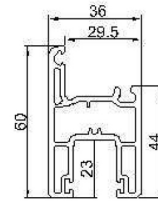

sash
JP-050-1
0.72Kg/m

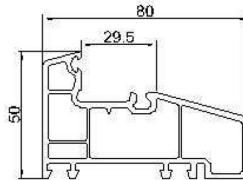

fixed frame
JP-142
1.01Kg/m

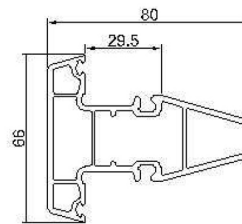

fixed mullion
JP-143
1.04Kg/m

80T Sliding System (Thickness 2.2mm)

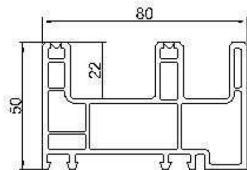

frame
JP-111T
1.29Kg/m

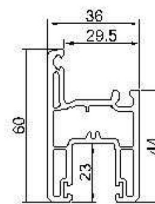

sash
JP-050-1T
0.82Kg/m

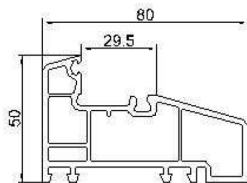

fixed frame
JP-142T
1.06Kg/m

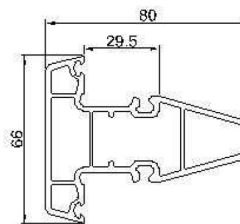

fixed mullion
JP-143T
1.11Kg/m

Section Drawing



80/80T Sliding System GB

5mm glass



GB19mm
JP-006
0.19Kg/m

12mm glass



GB12mm
JP-067
0.155Kg/m

14mm glass



GB10mm
JP-223
0.145Kg/m

17mm glass



GB7mm
JP-007
0.13Kg/m

80 Sliding System Auxiliary Profiles

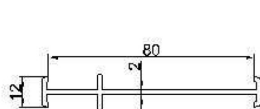

coupling
JP-010
0.35Kg/m

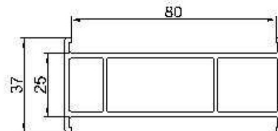

coupling
JP-043
0.80Kg/m

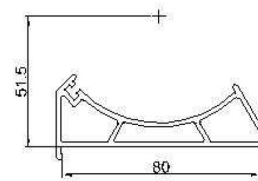

coupling
JP-092
0.78Kg/m

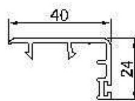

inter lock
JP-061
0.20Kg/m

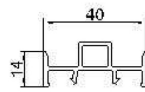

sash joint
JP-068
0.225Kg/m



screen sash
JP-089
0.55Kg/m

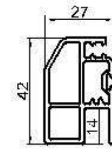

screen sash
JP-009-1
0.48Kg/m

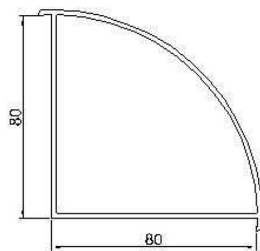

coupling
JP-011
0.92Kg/m

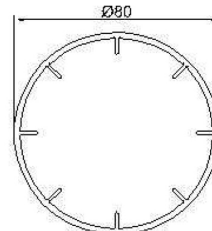

coupling
JP-093-1
0.85Kg/m

80 System Joint Drawing

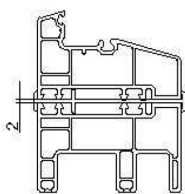

JP-010

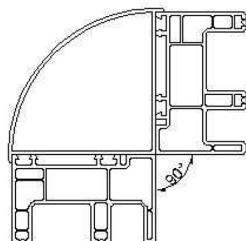

JP-011

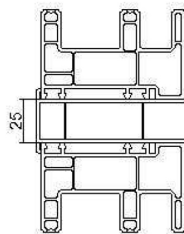

JP-043

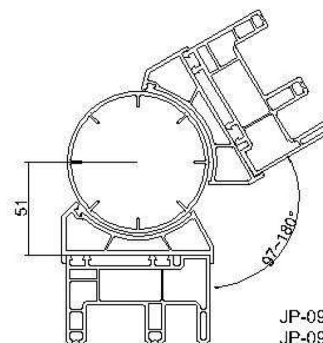

JP-092
JP-093-1

Structure Drawing

60 Low Sliding System

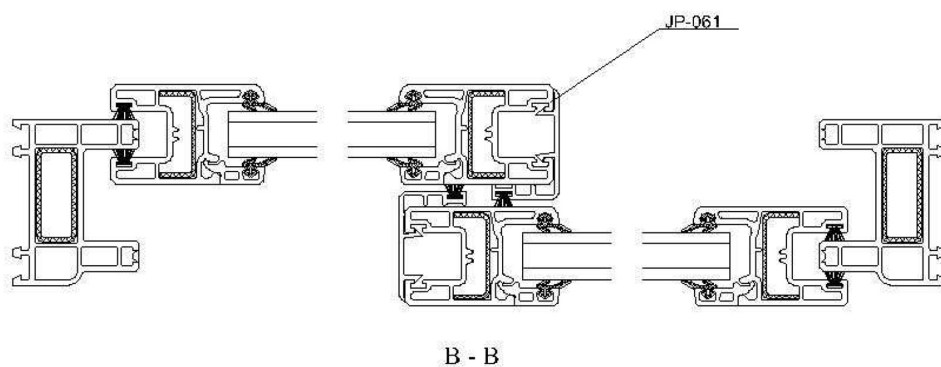
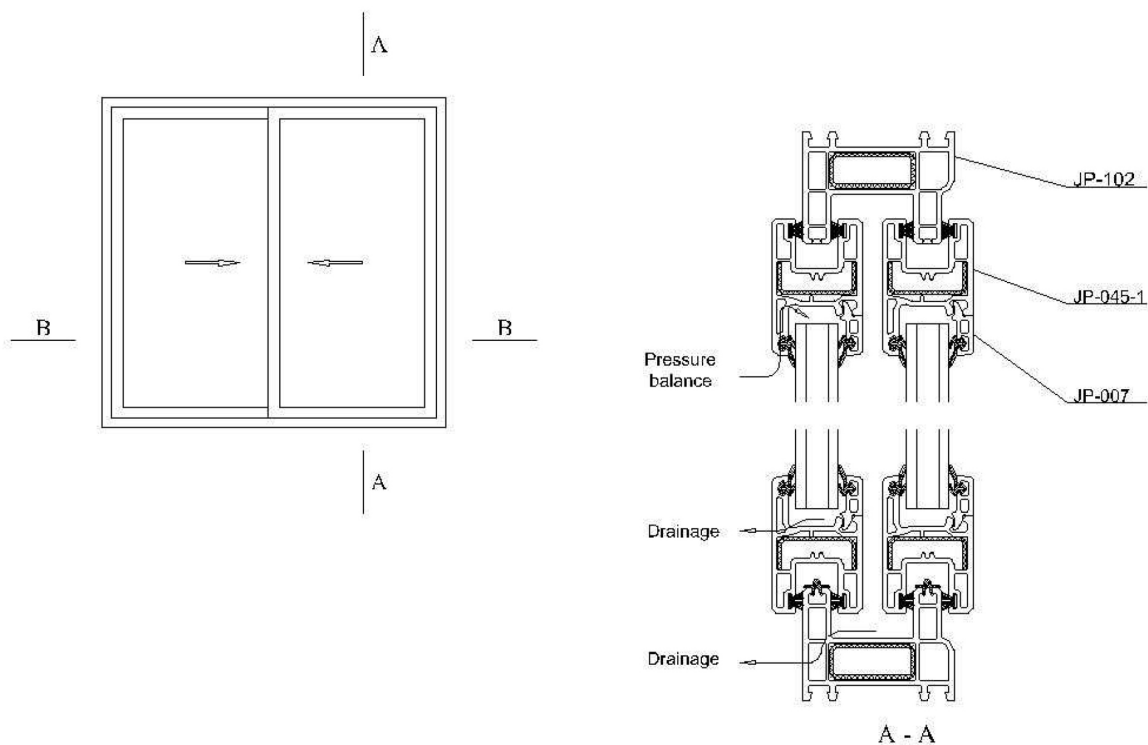

Structure Drawing

80 Low Sliding System

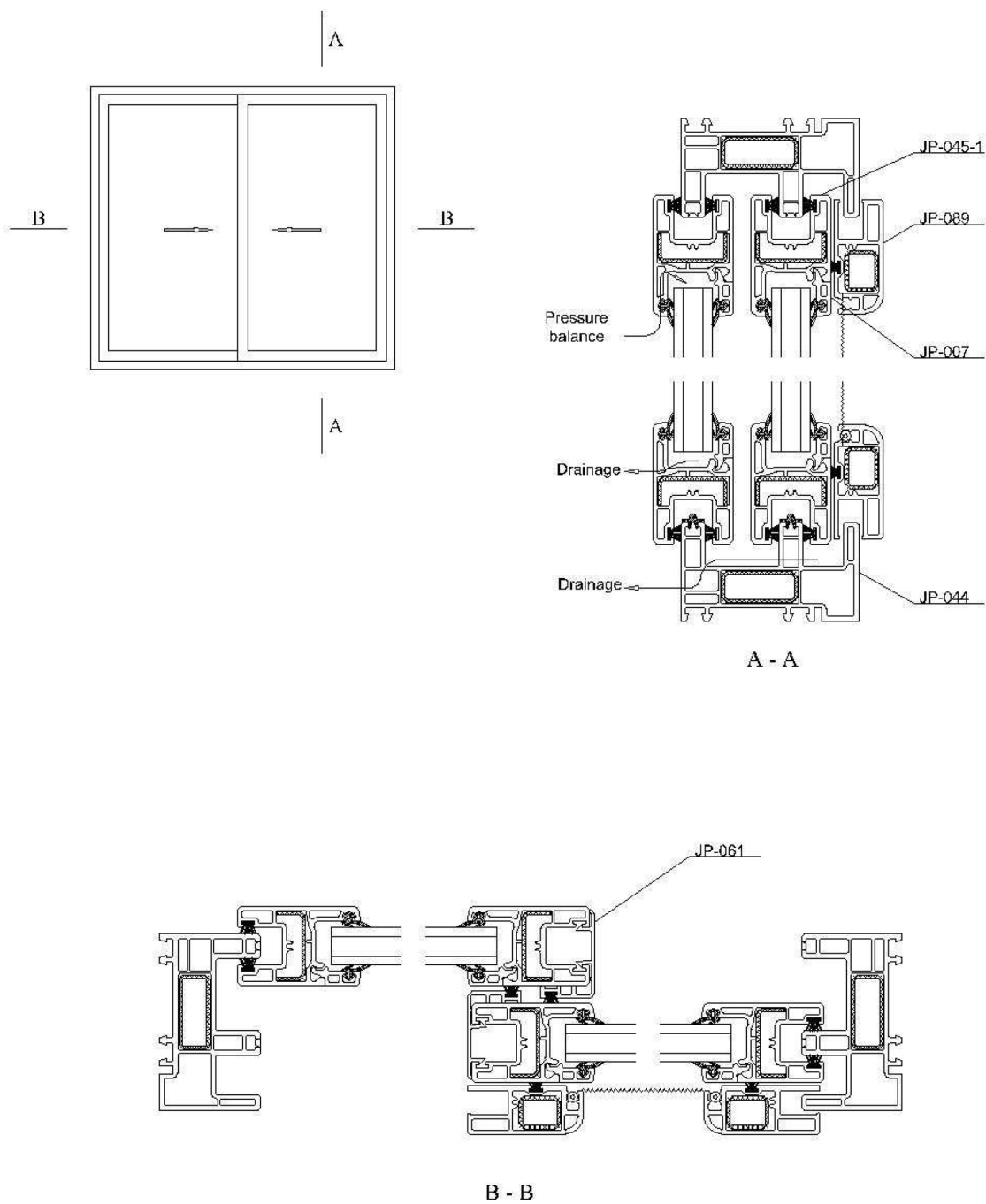

Structure Drawing

80 Sliding System

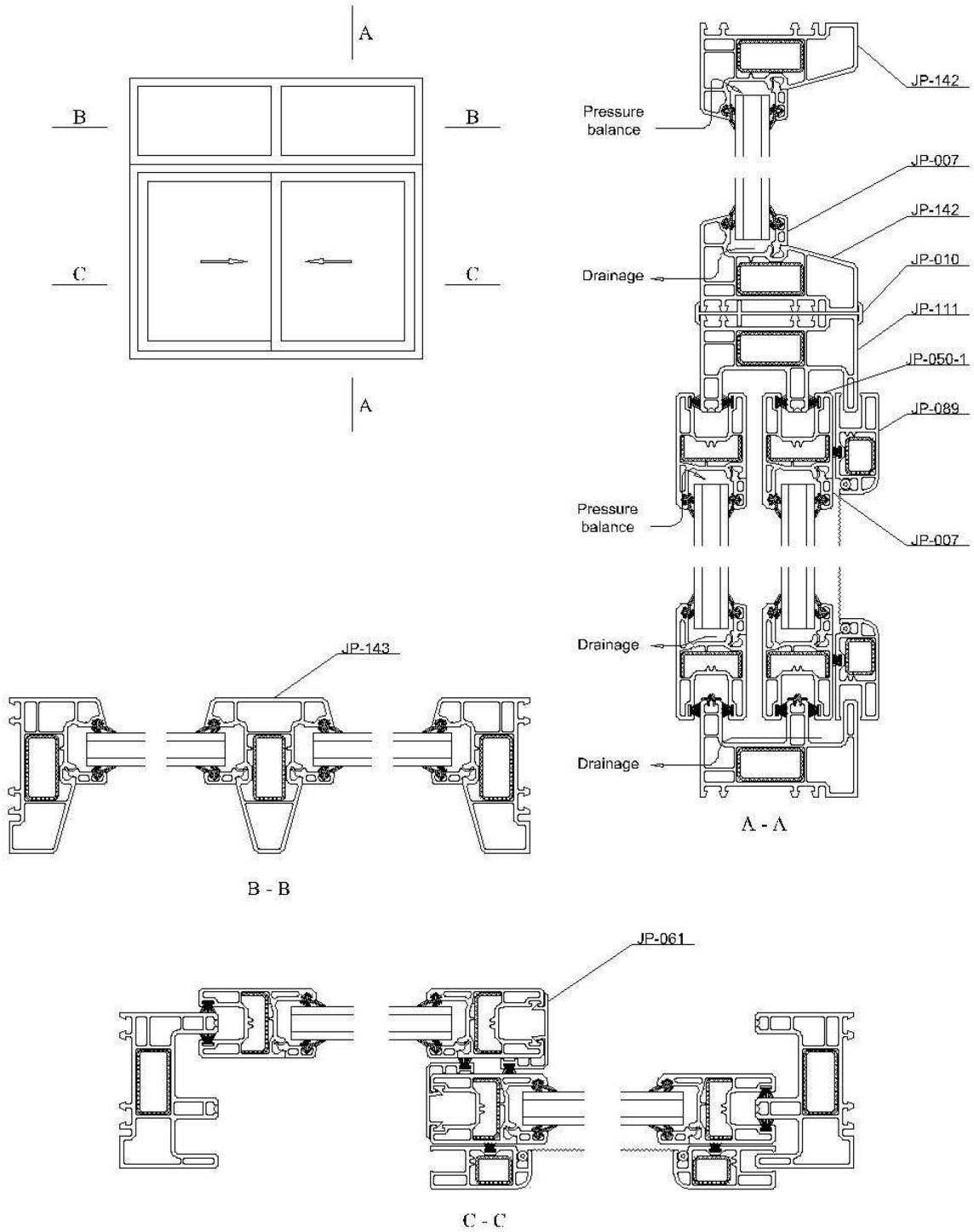

Section Drawing

88/60 Sliding System (Thickness 2.0mm)

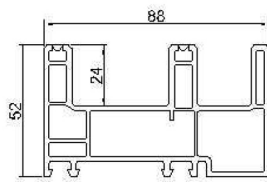

frame
JP-202-1
1.33Kg/m

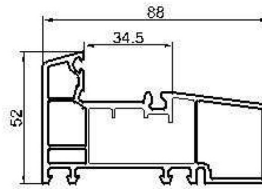

fixed frame
JP-203-1
1.09Kg/m

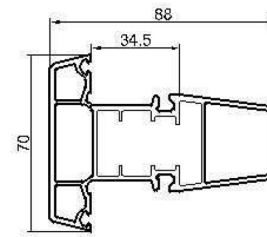

fixed mullion
JP-204-1
1.17Kg/m

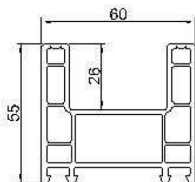

frame
JP-032-1
1.05Kg/m

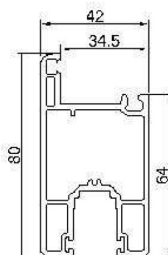

door sash
JP-034
1.01Kg/m

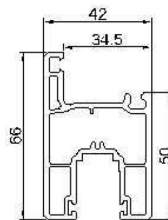

window sash
JP-033
0.91Kg/m

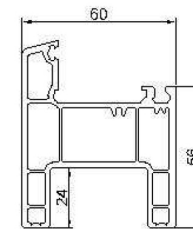

intergrated frame mullion
JP-298H
1.30Kg/m

88T/60T Sliding System (Thickness 2.2mm)

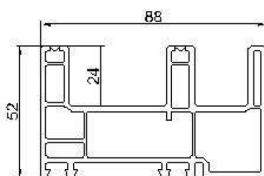

frame
JP-202-1T
1.40Kg/m

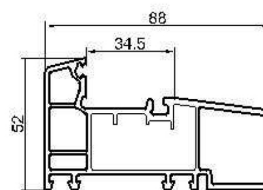

fixed frame
JP-203-1T
1.16Kg/m

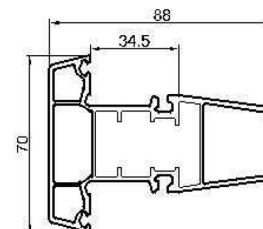

fixed mullion
JP-204-1T
1.27Kg/m

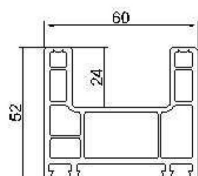

frame
JP-221T
1.03Kg/m

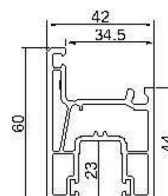

sash
JP-222T
0.90Kg/m

Section Drawing



109/60 Sliding System (Thickness 2.5mm)

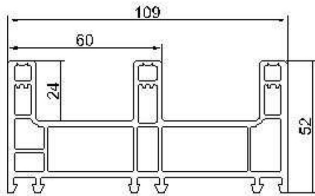

frame
JP-246H
1.72Kg/m

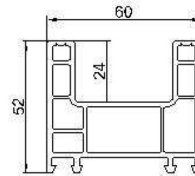

frame
JP-221H
1.07Kg/m

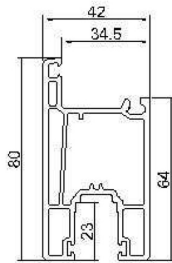

door sash
JP-034H
1.20Kg/m

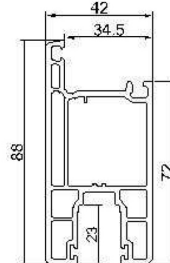

door sash
JP-331H
1.31Kg/m

60/88/88T Sliding System GB

5mm glass



GB25mm
JP-037
0.21Kg/m

17mm glass



GB12mm
JP-067
0.155Kg/m

19mm glass



GB10mm
JP-223
0.145Kg/m

22mm glass



GB7mm
JP-007
0.13Kg/m

88 System Joint Drawing

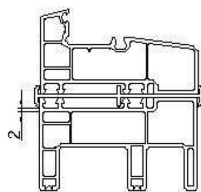

JP-079

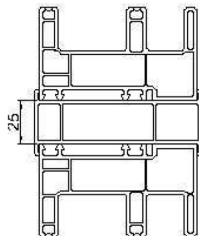

JP-060

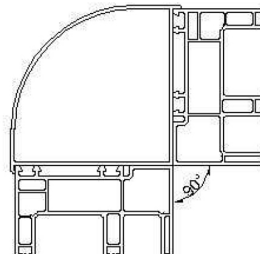

JP-080

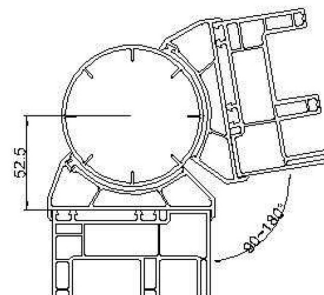

JP-121
JP-093-1

Section Drawing

88 Sliding System Auxiliary Profiles

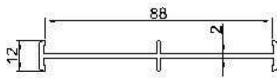

coupling
JP-079
0.38Kg/m

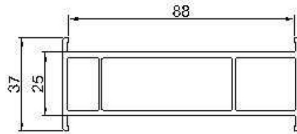

coupling
JP-060
0.90Kg/m

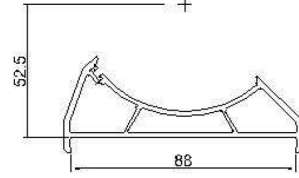

coupling
JP-121
0.75Kg/m

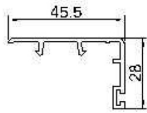

inter lock
JP-036
0.22Kg/m

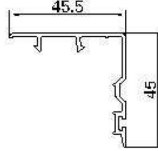

inter lock
JP-312
0.28Kg/m

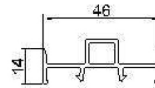

coupling
JP-048
0.25Kg/m

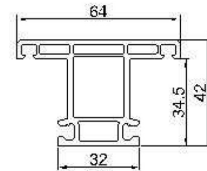

sash mullion
JP-035
0.72Kg/m

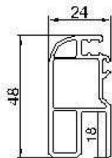

screen sash
JP-009-2
0.45Kg/m

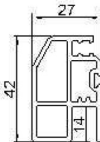

screen sash
JP-009-1
0.48Kg/m



screen sash
JP-074
0.61Kg/m



screen sash
JP-089
0.55Kg/m

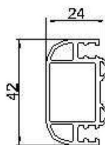

screen sash mullion
JP-334
0.43Kg/m
(fit with JP-009-2)

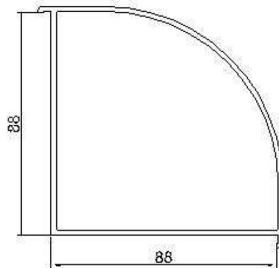

coupling
JP-080
1.19Kg/m

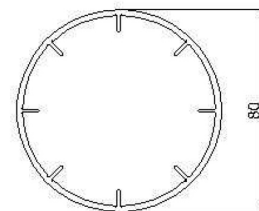

coupling
JP-093-1
0.85Kg/m

Structure Drawing

88 Sliding System

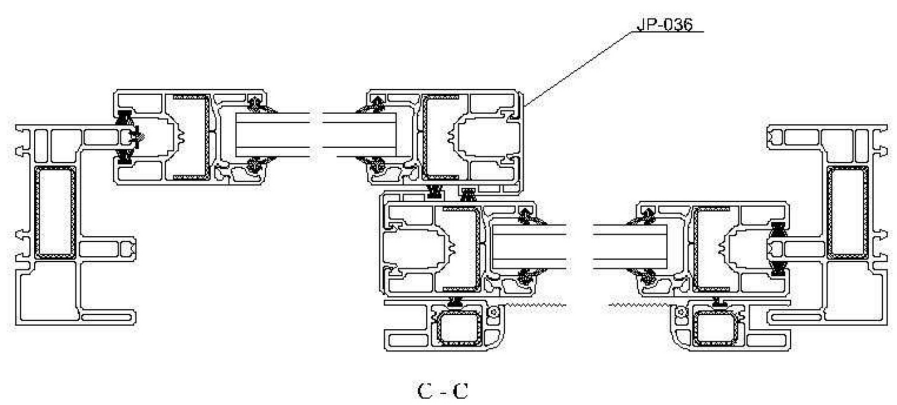
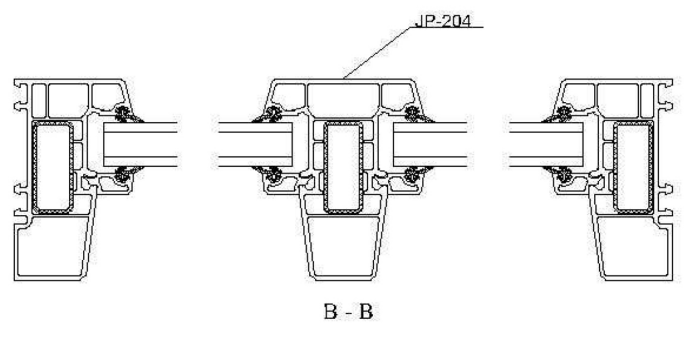
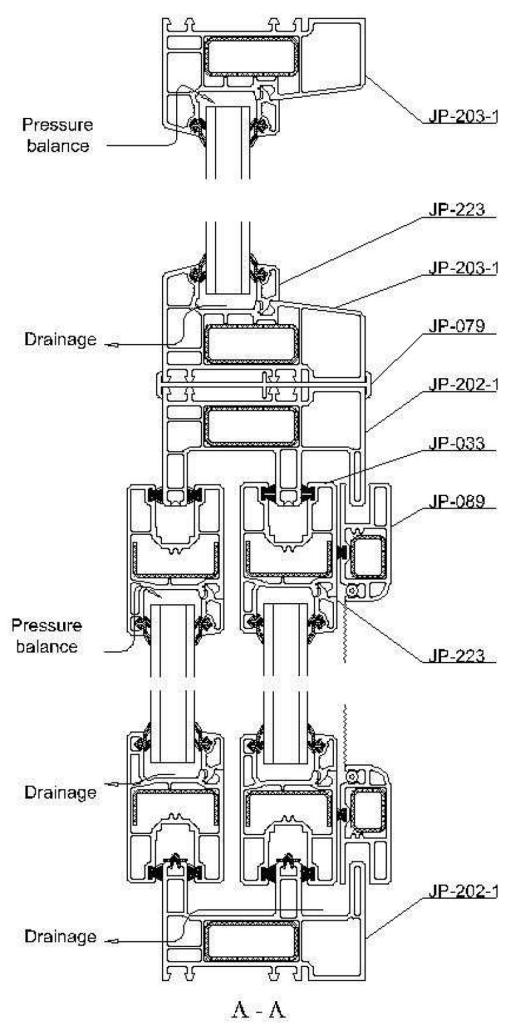
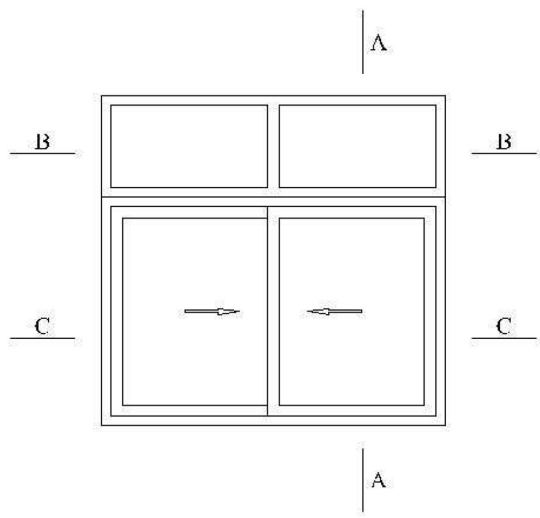

Structure Drawing

60 Sliding System

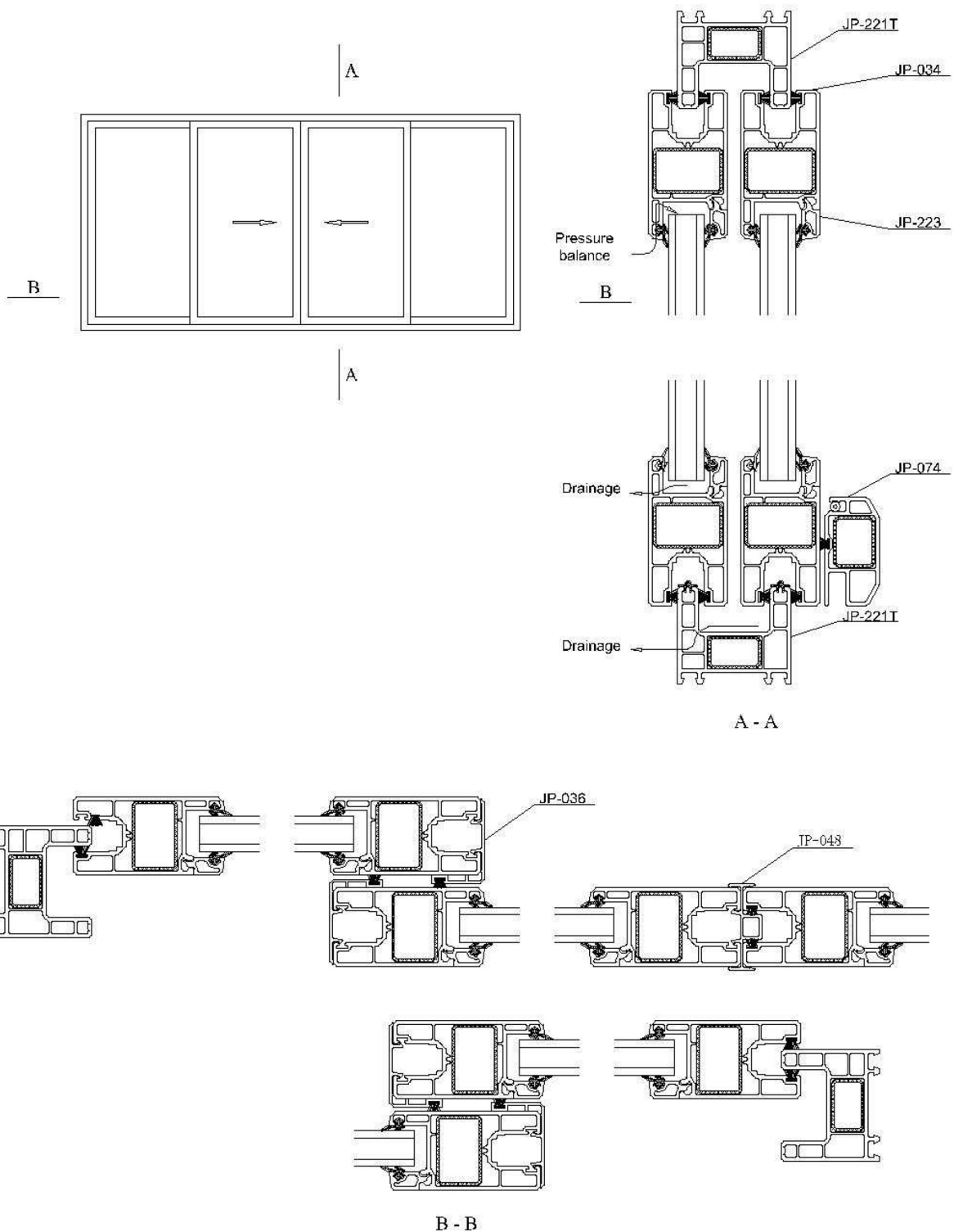

Structure Drawing

109 Sliding System

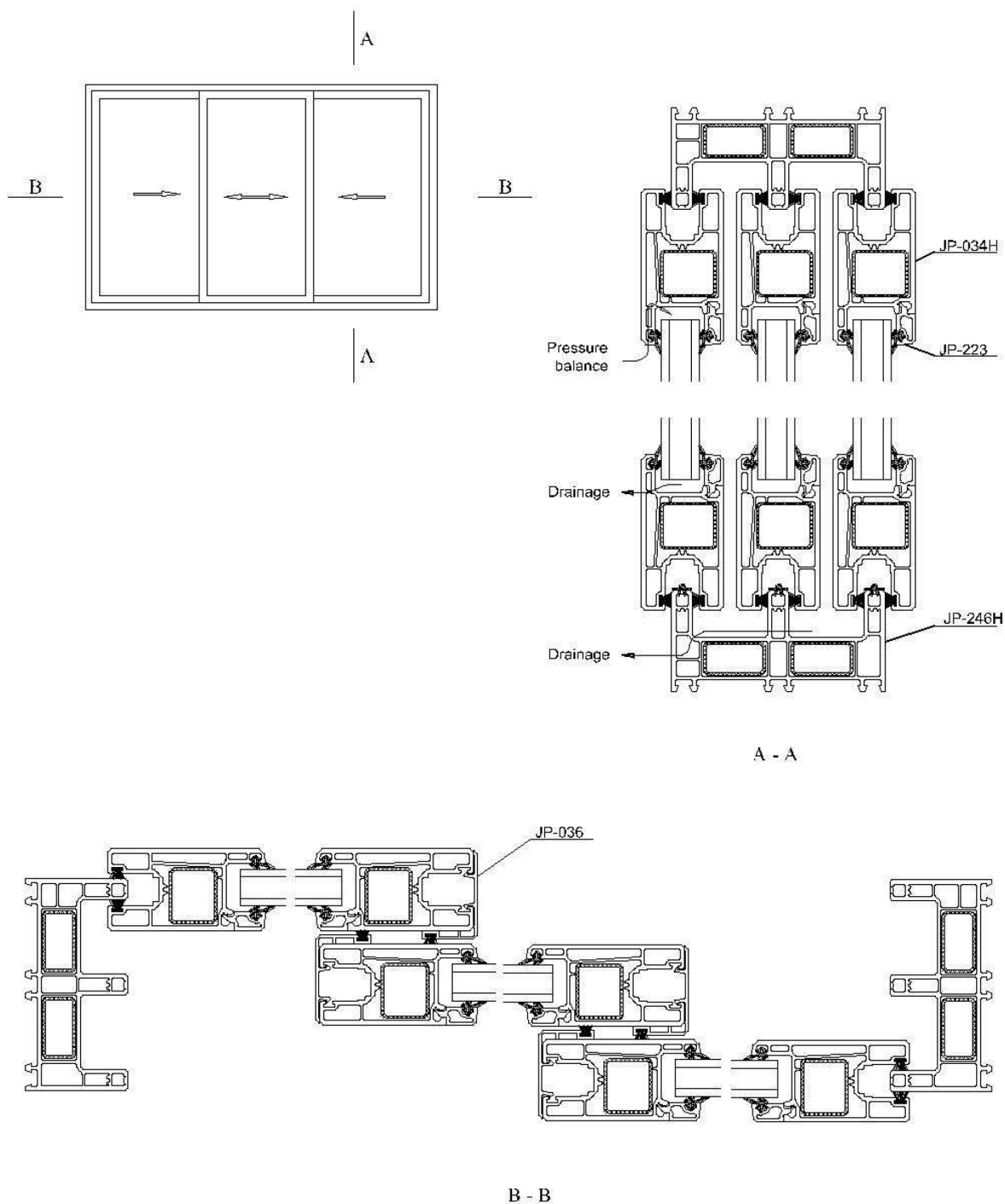

Structure Drawing

109 Sliding System

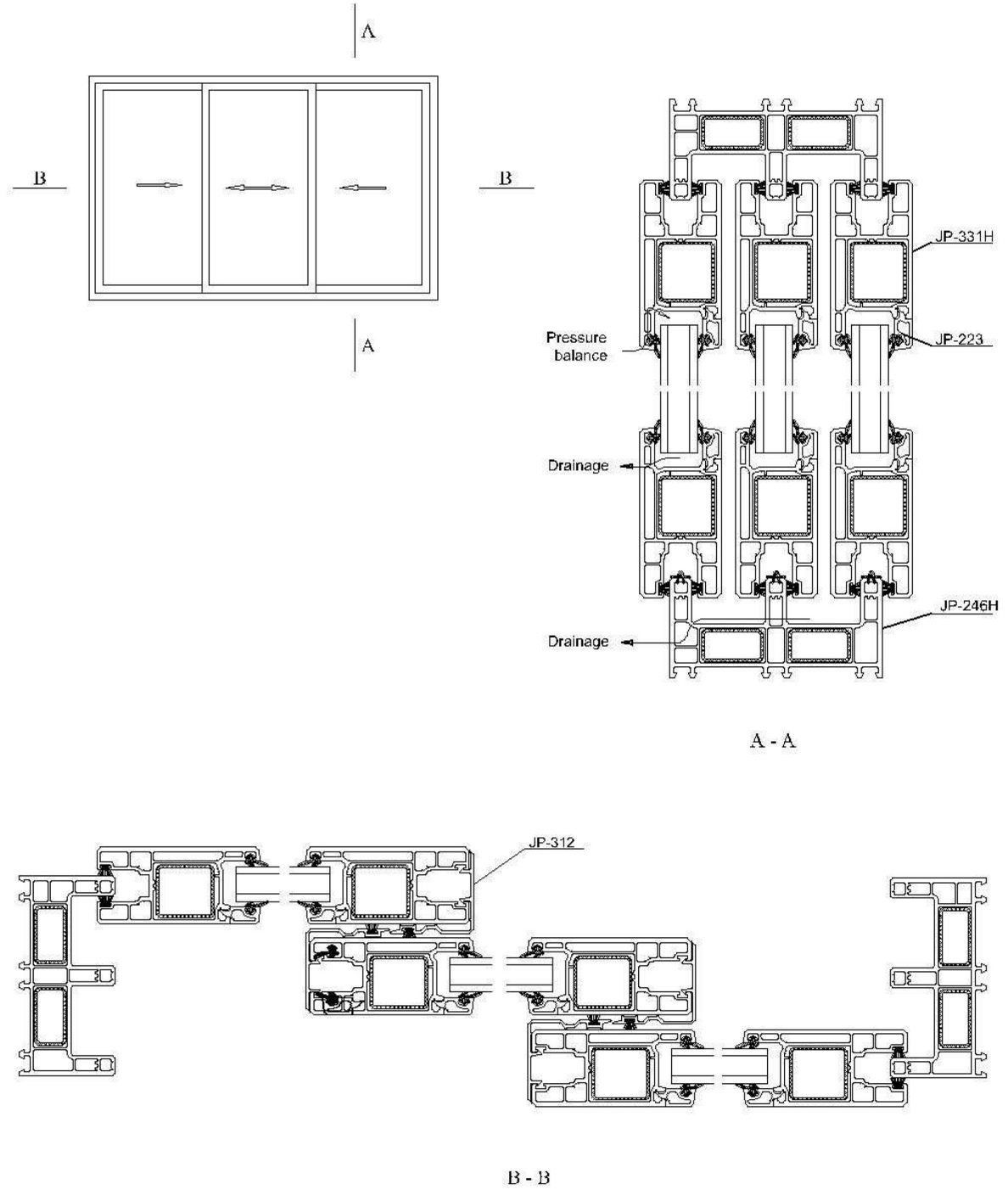

Steel Reinforcement Drawing



<p>JP-009-1</p>	<p>JP-008-2</p>	<p>JP-011</p>	<p>JP-013</p>	<p>JP-015 JP-015H</p>
<p>JP-016 JP-016H</p>	<p>JP-017 JP-017H</p>	<p>JP-017-1</p>	<p>JP-018 JP-018H JP-038 JP-038H</p>	<p>JP-019 JP-019H</p>
<p>JP-032-1</p>	<p>JP-033</p>	<p>JP-034</p>	<p>JP-034H</p>	<p>JP-035</p>
<p>JP-043</p>	<p>JP-044</p>	<p>JP-045-1</p>	<p>JP-049 JP-060</p>	<p>JP-050-1 P-050-1T</p>
<p>JP-061</p>	<p>JP-074</p>	<p>JP-089</p>	<p>JP-093-1</p>	<p>JP-102</p>
<p>JP-080</p>	<p>JP-111 JP-111T</p>	<p>JP-130</p>		<p>JP-135-1</p>
	<p>JP-135 JP-135H</p>	<p>JP-136 JP-136H</p>	<p>JP-137 JP-137H</p>	<p>JP-142/NP-143 JP-142T/NP-143T</p>
<p>JP-147 JP-147H</p>	<p>JP-163</p>	<p>JP-167</p>	<p>JP-171 JP-172</p>	<p>JP-195</p>

Steel Reinforcement Drawing



<p>JP-202-1 JP-202-1T JP-203-1 JP-203-1T JP-204-1 JP-204-1T</p>	<p>JP-212 JP-213</p>	<p>JP-219</p>	<p>JP-220</p>	<p>JP-220-1</p>
<p>JP-221T JP-221H</p>	<p>JP-222T</p>	<p>JP-230</p>	<p>JP-246H</p>	<p>JP-298H</p>
<p>JP-326M</p>	<p>JP-327M</p>	<p>JP-328M</p>	<p>JP-331H</p>	<p>JP-332</p>
<p>JP-333</p>	<p>JP-334</p>			

Window calculation

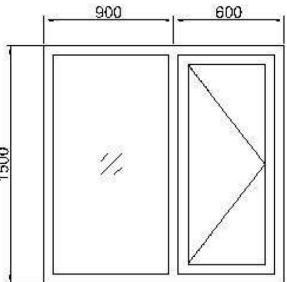
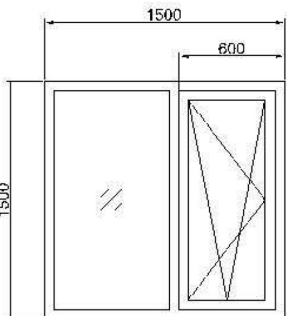
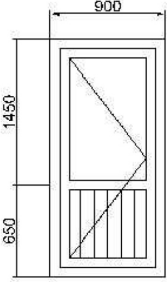
60 Outward window (thickness 2.0mm)							
	Name	Code	W	H	Length(m)	Kg/m	Weight(Kg)
	Frame	JP-017	1506	1506	6.024	1.000	6.020
	Mullion	JP-019		1462	1.462	1.020	1.490
	Sash	JP-015	564	1442	4.012	1.150	4.610
	GB	JP-023-1	842	1420	4.524	0.195	0.880
			438	1316	3.508	0.195	0.680
	Kg/window					13.680	
m²/T					164.47		
60 Inward window (thickness 2.0mm)							
	Name	Code	W	H	Length(m)	Kg/m	Weight(Kg)
	Frame	JP-017	1506	1506	6.024	1.000	6.020
	Mullion	JP-019		1462	1.462	1.020	1.490
	Sash	JP-016	564	1442	4.012	1.080	4.330
	GB	JP-023-1	842	1420	4.524	0.195	0.880
			452	1330	3.564	0.195	0.690
	Kg/window					13.410	
m²/T					167.78		
60 Outward door (thickness 2.0mm)							
	Name	Code	W	H	Length(m)	Kg/m	Weight(Kg)
	Frame	JP-017	906	2106	6.024	1.000	6.020
	Mullion	JP-019	706		0.706	1.020	0.720
	Sash	JP-018	842	2042	5.768	1.500	8.652
	Door panel	JP-020-1		490	2.450	0.710	1.740
	GB	JP-023-1	628	1296	3.848	0.195	0.750
			JP-021-1	628	496	2.248	0.240
Kg/window					18.420		
m²/T					102.58		

Window calculation

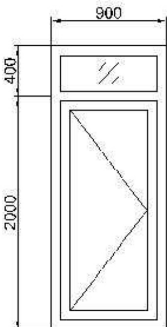
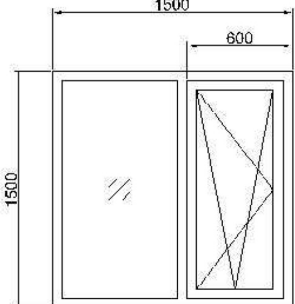
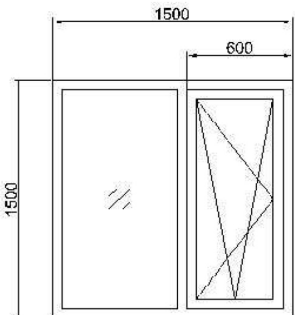
60H Inward door (thickness 2.5mm)								
	Name	Code	W	H	Length(m)	Kg/m	Weight(Kg)	
	Frame	JP-017H	906	2406	6.624	1.090	7.220	
	Mullion	JP-019H	862		0.862	1.130	0.970	
	Sash	JP-038H	842	1964	5.612	1.680	9.430	
	GB	JP-023-1	820	342	2.324	0.195	0.450	
			664	1986	4.900	0.195	0.960	
	Kg/window					19.030		
	m²/T					113.50		
66 Inward window (thickness 2.5mm)								
	Name	Code	W	H	Length(m)	Kg/m	Weight(Kg)	
	Frame	JP-135	1506	1506	6.024	1.260	7.590	
	Mullion	JP-136		1462	1.462	1.450	2.120	
	Sash	JP-137	564	1442	4.012	1.370	5.500	
	GB	JP-166	842	1420	4.524	0.250	1.130	
			446	1148	3.188	0.250	0.800	
	Kg/window					17.140		
	m²/T					131.23		
70M Inward window (thickness 2.8mm)								
	Name	Code	W	H	Length(m)	Kg/m	Weight(Kg)	
	Frame	JP-326M	1506	1506	6	1.480	8.920	
	Mullion	JP-327M		1452	1.452	1.640	2.380	
	Sash	JP-328M	549	1422	3.942	1.720	6.780	
	GB	JP-329	433	1296	3.458	0.200	0.690	
			827	1400	4.454	0.200	0.890	
	Kg/window					19.660		
	m²/T					114.42		

Window calculation

80 Sliding window (thickness 2.0mm)								
	Name	Code	W	H	Length(m)	Kg/m	Weight(Kg)	
	Frame	JP-111	1506	1006	5.024	1.170	5.880	
	Fixed frame	JP-142	1506	504	4.020	1.010	4.060	
	Sash	JP-050-1	745	924	6.676	0.720	4.810	
	Screen	JP-089	750	916	3.332	0.550	1.830	
	Coupling	JP-010	1500		1.500	0.350	0.530	
	GB	JP-007	1432	430	3.724	0.130	0.480	
			651	830	2.962	0.013	0.390	
	Kg/window					17.980		
	m²/T					125.15		
88T Sliding window (thickness 2.2mm)								
	Name	Code	W	H	Length(m)	Kg/m	Weight(Kg)	
	Frame	JP-202-1T	1506	1506	6.024	1.400	8.430	
	Sash	JP-222T	743	1420	8.652	0.900	7.790	
	Screen	JP-009-1	748	1414	4.324	0.480	2.080	
	Inter lock	JP-036		2828	0.220	0.620	0.124	
	GB	JP-223	748	1326	8.296	0.145	1.200	
	Kg/window					19.620		
m²/T					114.68			
109 Sliding door (thickness 2.5mm)								
	Name	Code	W	H	Length(m)	Kg/m	Weight(Kg)	
	Frame	JP-246H	2006	1806	7.624	1.720	13.110	
	Sash	JP-331H	682	1722	14.427	1.280	18.470	
	Inter lock	JP-312		1720	10.320	0.280	2.890	
	GB	JP-007	538	1578	12.699	0.130	1.650	
Kg/window					36.120			
m²/T					99.7			

I&E value and Kg/m list



Name	Code	Kg/m	Pack	I(mm ⁴)	E(mm)	Name	Code	Kg/m	Pack	I(mm ⁴)	E(mm)
60 casement system (thickness 2.0mm)						mullion	JP-220	0.94	6		
sash	JP-015	1.15	6	285370	39.67	mullion	JP-220-1	1.09	6		
sash	JP-016	1.08	6	226647	36.29	66 casement system (thickness 2.5mm)					
frame	JP-017	1.00	6	175220	33.94	frame	JP-135	1.26	6		
frame	JP-017-1	1.13	6	248863	38.01	frame	JP-135-1	1.34	6		
sash	JP-018	1.50	5	753994	52.90	mullion	JP-136	1.45	6		
mullion	JP-019	1.02	6	218172	36.00	sash	JP-137	1.37	6		
sash	JP-038	1.45	4	748610	52.89	sash	JP-212	1.79	4		
Z mullion	JP-147	1.01	6	224659	36.00	sash	JP-213	1.73	4		
60H casement system (thickness 2.5mm)						66H casement system (thickness 2.5mm)					
sash	JP-015H	1.25	6	314457	39.98	frame	JP-135H	1.36	6		
sash	JP-016H	1.18	6	229199	36.30	mullion	JP-136H	1.54	6		
frame	JP-017H	1.09	6	186230	33.65	sash	JP-137H	1.45	6		
sash	JP-018H	1.65	5	842101	53.77	66/66H casement system auxiliary profiles					
mullion	JP-019H	1.13	6	236384	36.00	coupling	JP-031-1	0.11	40		
sash	JP-038H	1.68	4	838762	53.76	pad	JP-138	0.20	24		
Z mullion	JP-147H	1.16	6	237201	36.00	GB10mm	JP-139	0.19	30		
mullion	JP-298H	1.30	6			GB10mm	JP-140	0.20	30		
60/60H casement system auxiliary profiles						coupling	JP-163	0.96	4		
coupling	JP-013	0.62	8			GB25mm	JP-166	0.25	24		
panel	JP-020-1	0.71	6			coupling	JP-167	0.70	8		
panel	JP-020-2	0.85	6			coupling	JP-214	0.58	10		
GB31mm	JP-021-1	0.24	32			coupling	JP-219	0.95	6		
GB35mm	JP-022-1	0.27	24			70M casement system (thickness 2.8mm)					
GB20mm	JP-023-1	0.195	32			frame	JP-326M	1.48	6	356783	40.50
coupling	JP-031-1	0.11	40			mullion	JP-327M	1.64	6	463924	43.00
mullion	JP-046	0.69	6			sash	JP-328M	1.72	6	432082	41.30
coupling	JP-049	0.68	8			70M casement system auxiliary profiles					
coupling	JP-051	0.68	4			coupling	JP-031-1	0.11	40		
coupling	JP-090	0.53	10			GB15mm	JP-329	0.20	30		
GB23mm	JP-106	0.20	32			GB22mm	JP-330	0.235	30		
louver	JP-117	0.28	24			coupling	JP-332	0.66	8		
louver	JP-118	0.22	24			coupling	JP-333	1.03	4		
coupling	JP-130	1.30	6								
GB18mm	JP-181	0.185	32								
frame	JP-195	0.810	6	70527	18						
frame GB	JP-196	0.180	30								
coupling	JP-215	0.25	16								

